

# FP3700-T41 Installation Guide



## WARNINGS

- When connecting the FP3700-T41 (hereafter referred to as the "FP")'s power cord terminals to the FP unit's Terminal Block, check first that the FP unit's power supply is completely turned OFF, via a breaker, or similar unit.
- Whenever changing the backlight, to prevent electric shocks and burns, be sure to unplug the FP unit's power cord and wear protective gloves.
- Do not open or remodel the FP unit, since it may lead to a fire or electric shock.
- Do not use power beyond the FP unit's specified voltage range. Doing so may cause a fire or an electric shock.
- Do not use the FP in an environment where flammable gases are present, since operating the FP may cause an explosion.
- Do not use the FP as a warning device for critical alarms that can cause serious operator injury, machine damage or production stoppage. Critical alarm indicators and their control/activator units must be designed using stand-alone hardware and/or mechanical interlocks.
- Do not use FP touch panel switches in life-related or important disaster prevention situations. For safety related switches, such as an emergency switch, be sure to use a separate mechanical switch.
- After the FP's backlight burns out, unlike the FP's "Standby Mode", the touch panel is still active. If the operator fails to notice that the backlight is burned out and touches the panel, a potentially dangerous machine mis-operation can occur. Therefore, do not use FP touch switches for the control of any equipment safety mechanisms, such as Emergency Stop switches, etc. that protect humans and equipment from injury and damage.  
If your FP's backlight suddenly turns OFF, use the following steps to determine if the backlight is actually burned out.
  - 1) If your current FP application is not set to turn the backlight OFF, and the screen has gone blank, your backlight is burned out.
  - 2) If your current FP application is set to turn the backlight OFF, if touching the screen does not cause the display to reappear, your backlight is burned out.
- To prevent operator injury or machine damage, be sure to design your machine operation system so that the machine will not malfunction due to a communication fault between the FP and its host controller.
- The FP is not appropriate for use with aircraft control devices, aerospace equipment, central trunk data transmission (communication) devices, nuclear power control devices, or medical life support equipment, due to these devices' inherent requirements of extremely high levels of safety and reliability.
- When using the FP with transportation vehicles (trains, cars and ships), disaster and crime prevention devices, various types of safety equipment, non-life support related medical devices, etc., redundant and/or failsafe system designs should be used to ensure the proper degree of reliability and safety.

To prevent this unit from malfunctioning:

- Do not strike the FP touch panel with a hard or heavy object, or press on the touch panel with too much force, since it may damage the display.
- Do not install the FP where the temperature will exceed the specified range.
- Be sure that water, liquids or metal particles do not enter the FP, since it may cause a malfunction or a short circuit.
- Avoid installing the FP where sudden, large changes in temperature may occur. These changes may cause condensation to form inside the unit, possibly causing a malfunction.
- To prevent excessive heat from building up inside the FP, do not install it where its ventilation holes may be blocked. Also, do not install or store the FP near high temperature equipment.
- Do not install or store the FP where direct sunlight or high levels of dust exist.
- Since the FP is a precision instrument, do not install or store it where either strong shocks or excessive vibration may occur.
- Do not install or store the FP in an area containing chemicals or chemical fumes.
- Do not use paint thinner or organic solvents to clean the FP unit's case or screen.
- After turning the FP OFF, be sure to wait a few seconds before turning it ON again. If the FP is started too soon, it may not start up correctly.

## UL/c-UL (CSA) Application Notes

The FP3700-T41 is a UL/c-UL (CSA) listed product. (UL File No.E220851)

**This unit conforms as a product to the following standards:**

- **UL508** Industrial Control Equipment
- **CAN/CSA C22.2 No.14-M1995** Industrial Control Equipment

FP3700-T41 (UL Registration Model: 3180040-01)

<Cautions>

- The FP must be used as a built-in component of an end-use product.
- This unit should be installed in the front face of a metal panel.
- If this unit is installed so as to cool itself naturally, be sure to install it in a vertical panel. Also, be sure that the FP unit is mounted at least 100 mm away from any adjacent structures or equipment. If these requirements are not met, the heat generated by the FP unit's internal components may cause the unit to fail to meet UL/c-UL standard requirements.

## CE Marking Notes

The FP3700-T41 is a CE marked product that conforms to EMC directives and Low Voltage directives EN55011 Class A, EN61000-6-2 and EN60950-1 First Edition.

\* For detailed CE marking information, please contact your local FP distributor.

<Cautions>

- The FP unit is intended for indoor use only.
- When an end-user product will include the FP, be sure to design the FP unit's power cut-off switch as a separate disconnect device and locate it where the operator can easily reach it.
- Be sure the unit the FP is built into uses an EN60950-1 approved structure.

# Package Contents

The following items are included in the FP unit's package. Before using the FP, please confirm that all items listed here are present.

■ **FP unit  
(FP3700-T41)**

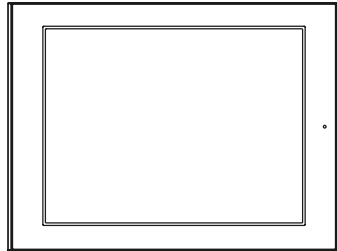

- **CD-ROM(1)**  
Contains the FP3700-T41 User Manual
- **Installation Gasket (1)**
- **Installation Brackets (4/set, 2sets)**
- **FP3700-T41 Installation Guide (1)**  
(this manual)
- **AC Power Cord(1)**
- **Cord Clamp(1)**
- **USB Cable Strap(1)**

This unit has been carefully packed, with special attention to quality. However, should you find anything damaged or missing, please contact your local FP distributor immediately.



*The Power Cord included in the FP unit's package is designed only for AC100V or AC115V use. Any other voltage will require a different cord.*

## Options

- **Cables**
- **Maintenance Parts**
- **Touch panel driver software**

### 1 Part Names

Front View

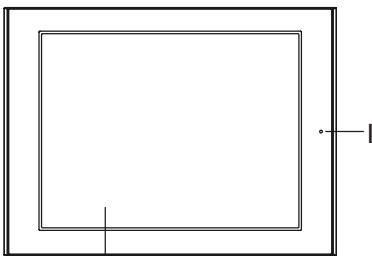

A, B

Rear View

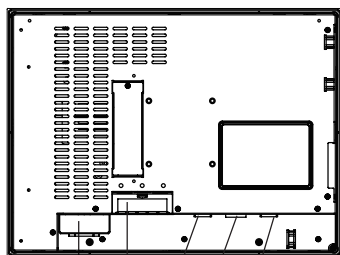

C D E F G H



Bottom View

**A: TFT Color LCD**

Acts as a display monitor for your host.

**B: Touch Panel**

Allows you to switch screens or write data to the host.

**C: AC Connector**

Provides the input and ground terminals for a power cable.

**D: Setting Switch (Dip switches)**

Used to change the settings of each operation mode.

**E: VGA Interface (analog RGB) Connector**

Connector for analog RGB interface

**F: DVI-D Interface Connector**

Connector for DVI-D interface

**G: RS-232C Connector**

Connector for RS-232C (serial) interface. Used for sending touch panel data to the host, and for receiving commands from the host.

**H: USB Connector**

Connector for USB interface. Used for both sending touch panel data to the host, and receiving commands from the host.

**I: Front LED**

Used to indicate the condition of the power supply, a backlight burnout or image signal input.

## 2 Dimensions

Unit:mm [in]

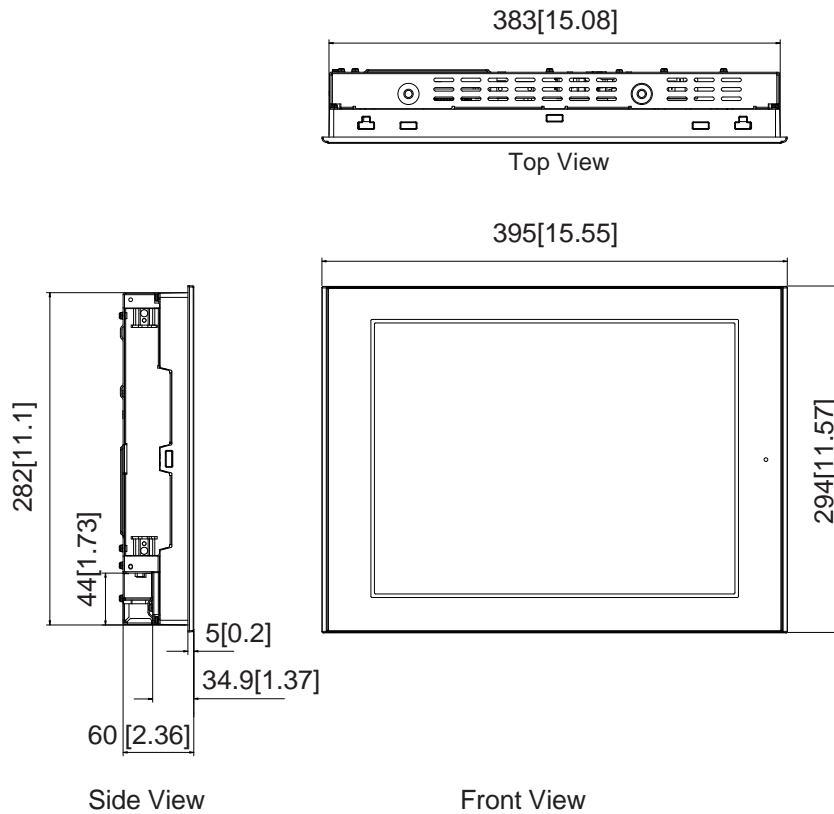

## 3 Dip Switches

The dip switches are under the cover shown below.

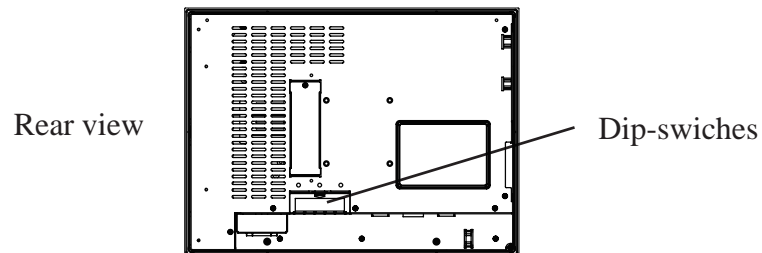

After changing your FP unit's Dip Switch settings, please reboot your FP.

## SW1

<input type="checkbox"/>	8	SW1-8	Reserved (Set this switch to OFF)
<input type="checkbox"/>	7	SW1-7	Reserved (Set this switch to OFF)
<input type="checkbox"/>	6	SW1-6	Reserved (Set this switch to OFF)
<input type="checkbox"/>	5	SW1-5	Switch between analog RGB and DVI-D input
<input type="checkbox"/>	4	SW1-4	Reserved (Set this switch to OFF)
<input type="checkbox"/>	3	SW1-3	Reserved (Set this switch to OFF)
<input type="checkbox"/>	2	SW1-2	Display/hide the OSD
<input type="checkbox"/>	1	SW1-1	Switch between USB and RS232C for touch panel data transmission.

**ON**

- **SW1-1**

Dip Switch SW1-1 is used to set the touch panel data input (command control) method to either USB or RS-232C.

When the switch is set to OFF, data output and command input/output are performed via RS-232C. When the switch is set to ON, USB is used.

The default setting is OFF. (RS-232C)

- **SW1-2**

Dip Switch SW1-2 is used to display or hide the OSD.

To hide the OSD, set the switch to ON. To display the OSD, set the switch to OFF.

The default setting is OFF. (OSD is displayed.)

- **SW1-5**

Dip Switch SW1-5 is used to change the image input method.

When the switch is set to ON, DVI-D image input method is used. When the switch is set to OFF, the analog RGB image input method is used.

The default setting is OFF. (Analog RGB is used.)

## 4 Interfaces

### ■ Analog RGB Interface

Input signal type	Analog RGB
Input signal characteristic	Image signal: analog RGB Synchronous signal: TTL level, negative true or positive true Scanning type: non-interlace
Setting by OSD (On Screen Display)	CONTRAST BLACK LEVEL H-POS V-POS OSD H-POSITION PHASE BACKLIGHT DEFAULT (ALL CLEAR)

The number of dots (pixels) displayed are as follows:

Size	H Sync. (kHz)	V Sync. (Hz)	Dot Clock (MHz)	Screen Resolution Expansion (H: Horizontal) (V: Vertical)	Display Resolution
640×400	24.827	56.000	21.053	×1.6 (H) ×1.92 (V)	1024×767
640×400	31.469	70.000	25.175		
640×480	31.469	59.992	25.175	×1.6	1024×768
640×480	37.500	75.000	31.500		
640×480	35.000	66.667	30.240		
720×400 <sup>*1</sup>	31.469	70.000	28.320	×1.42 (H) ×1.92 (V)	1023×767
800×600	37.879	60.317	40.000	×1.28	1024×768
800×600	46.875	75.000	49.500		
1024×768	48.363	60.004	65.000	×1.0	1024×768
1024×768	56.476	70.069	75.000		
1024×768	60.023	75.029	78.750		

*\*1 When you use this resolution, select "720 x 400 Display Resolution 720 x 400 DSP" in the OSD (On Screen Display) system setting.*

### Pin Assignments and Signal Names for Analog RGB

Pin No.	Signal Name	Condition	Pin Location
1	Analog R	R signal input	
2	Analog G	G signal input	
3	Analog B	B signal input	
4	Reserved	NC (spare for input)	
5	Digital grounding	Digital signal GND	
6	Return R	R signal GND	
7	Return G	G signal GND	
8	Return B	B signal GND	
9	Reserved	NC (spare for input)	
10	Digital grounding	Digital signal GND	
11	Reserved	NC (spare for input)	
12	Reserved	NC (spare for input)	
13	H. SYNC	Horizontal synchronous signal	
14	V. SYNC	Vertical synchronous signal input	
15	Reserved	NC (spare for input)	

Connector: Mini Dsub 15 pin male

Connector set screw: Inch type (4-40)

Cable: RGB cable manufactured by Digital Electronics Corporation of Japan,  
FP-CV02-45 <4.5m> (VGA standard)



***If a cable other than the specified RGB cable is used, product performance cannot be guaranteed due to the possibility of noise interfering with the FP unit's operation.***

## DVI-D Interface

Input signal type	DVI-D
Setting by OSD (On Screen Display)	H-POS V-POS BACKLIGHT DEFAULT (ALL CLEAR)

The number of dots (pixels) displayed are as follows:

Size	H Sync. (kHz)	V Sync. (Hz)	Dot Clock (MHz)	Screen Resolution Expansion (H: Horizontal) (V: Vertical)	Display Resolution
640×400	24.827	56.000	21.053	×1.6 (H) ×1.92 (V)	1024×767
640×400	31.469	70.000	25.175		
640×480	31.469	59.992	25.175	×1.6	1024×768
640×480	37.500	75.000	31.500		
640×480	35.000	66.667	30.240		
720×400 <sup>*1</sup>	31.469	70.000	28.320	×1.42 (H) ×1.92 (V)	1023×767
800×600	37.879	60.317	40.000	×1.28	1024×768
800×600	46.875	75.000	49.500		
1024×768	48.363	60.004	65.000	×1.0	1024×768
1024×768	56.476	70.069	75.000		
1024×768	60.023	75.029	78.750		

\*1 When you use this resolution, select "720 x 400 Display Resolution 720 x 400 DSP" in the OSD (On Screen Display) system setting.

### Pin Assignments and Signal Names for DVI-D

Pin No.	Signal Name	Pin No.	Signal Name	Pin Location
1	TMDS DATA2-	13	NC	
2	TMDS DATA2+	14	NC	
3	TMDS DATA2/4 SHIELD	15	GND (+5V)	
4	NC	16	Hot Plug Detect	
5	NC	17	TMDS DATA0-	
6	DDC Clock	18	TMDS DATA0+	
7	DDC Data	19	TMDS DATA0/5 SHIELD	
8	NC	20	NC	
9	TMDS DATA1-	21	NC	
10	TMDS DATA1+	22	TMDS CLOCK SHIELD	
11	TMDS DATA1/3 SHIELD	23	TMDS CLOCK+	
12	NC	24	TMDS CLOCK-	

Connector: DVI-D 24-pin male

Connector set screw: Inch type (4-40)

Cable: DVI-D cable manufactured by Digital Electronics Corporation of Japan  
(FP-DV01-50 <5 m>, FP-DV01-100 <10 m>)



- **The FP-DV01-100 can be used only when connected to a PS-2000B unit. When using the FP-DV01-100, be sure to turn the PS-2000B's internal dipswitch 4 ON. (When using the FP-DV01-50, turn this switch OFF.)**
- **If a cable other than the specified DVI-D cable is used, product performance cannot be guaranteed due to the possibility of noise interfering with the FP unit's operation.**



## Serial Interface

Serial Interface	Baud rate: 9600 bps Data length: 8 bits Parity: none Stop bit: 1
------------------	---

### Pin Assignments and Signal Names for Serial Interface

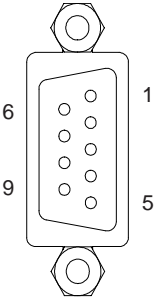
Pin No.	Signal Name	Condition	Pin Location
1	CD	Carrier Detect <sup>*1</sup>	
2	RD	Receive Data (FP->Host)	
3	SD	Send Data (FP<-Host)	
4	DTR	Data Terminal Ready <sup>*1</sup>	
5	GND	Ground	
6	DSR	Data Set Ready <sup>*1</sup>	
7	RS	Request to Send (FP<-Host)	
8	CS	Clear to Send (FP->Host)	
9	NC	(Used internally)	

Connector : Dsub 9 pin female

Connector set screw : Inch type (4-40)

Cable : SIO cable manufactured by Digital Electronics Corporation of Japan  
(FP61V-IS00-O)

*\*1 The CD, DTR, and DSR are connected together inside of the FP.*

### Concerning Signal Names

Signal names used for the serial interface on FP units are designed to match the pin order used on most PC serial interfaces, so that a straight cable can be used to connect the two. Therefore, connect each pin's signal to the same signal name on the PC side.

For example, pin #2 'RD' should be connected to the 'RD' input terminal on the PC's connector.

Refer to the FP3700-T41 User Manual's section "2-4 Cable Diagrams" for each signal's direction.



***If a cable other than the specified RS-232C cable is used, product performance cannot be guaranteed due to the possibility of noise interfering with the FP unit's operation.***

## USB Interface

### Pin Assignments and Signal Names for USB Interface

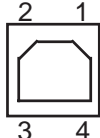
Pin NO.	Signal Name	Condition	Pin Location
1	USB1-5V	+5VIN	
2	USBD1(-)	USBdata(-)	
3	USBD1(+)	USBdata(+)	
4	GND	Ground	

Communication : Low speed Device

Connector : B type connector

Cable : USB cable manufactured by Digital Electronics Corporation of Japan  
(FP-US00)



***If a cable other than the specified USB cable is used, product performance cannot be guaranteed due to the possibility of noise interfering with the FP unit's operation.***



# 5 Installation

## ■ Confirm the Installation Gasket's Positioning

It is strongly recommended that you use the gasket. It absorbs vibration in addition to repelling water.

Place the FP on a level surface with the display panel facing downward. Check that the FP's installation gasket is seated securely into the gasket's groove, which runs around the perimeter of the panel's frame.



- **Before installing the FP into a cabinet or panel, check that the installation gasket is securely attached to the unit.**
- **A gasket which has been used for a long period of time may have scratches or dirt on it, and could have lost much of its dust and drip resistance. Be sure to change the gasket periodically or when scratches or dirt become visible.**
- **Be sure to use gasket model CA3-WPG15-01.**
- **Be sure the gasket's seam is not inserted into any of the unit's corners, only in the straight sections of the groove. Inserting it into a corner may lead to its eventually tearing.**
- **To ensure the installation gasket's maximum level of moisture resistance, be sure the gasket's seam is inserted as shown into the panel's bottom face.**

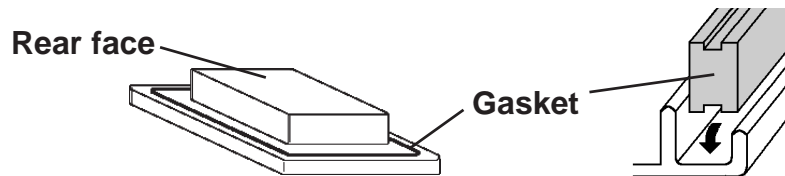

## ■ Create a Panel Cut and insert the FP into the panel from the front

Unit: mm [in]

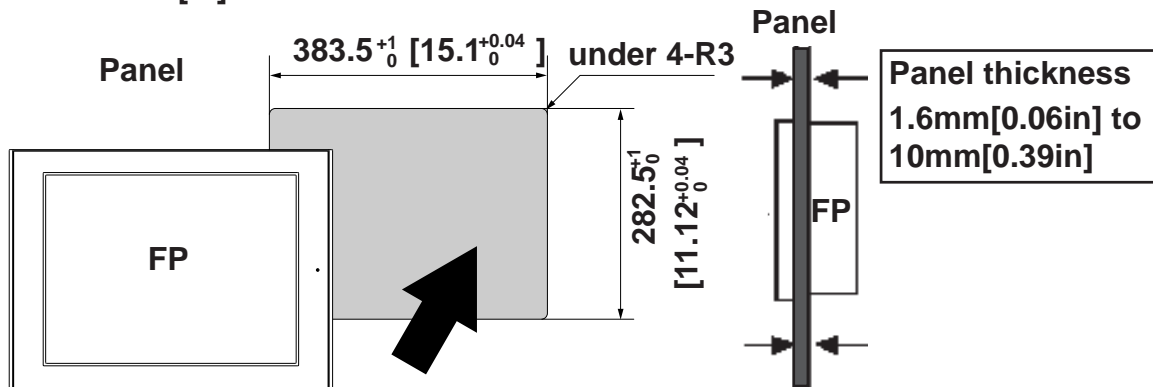

## ■ Attach the Installation Fasteners from Inside the Panel

The following figures show the eight(8) fastener insertion slot locations. Insert each fastener's hook into the slot and tighten it with a screwdriver.

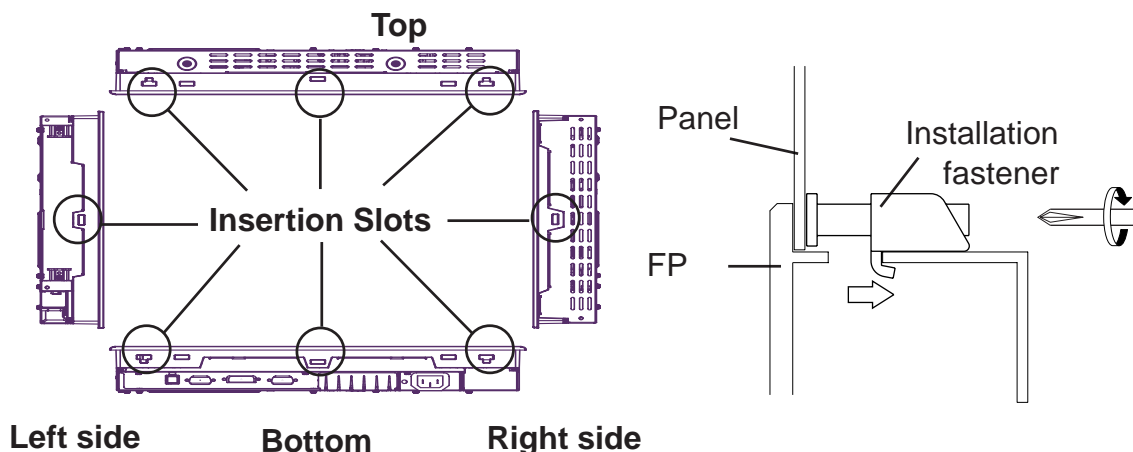



- **Tightening the screws with too much force can damage the FP unit's case.**
- **The necessary torque is 0.5N•m.**

## 6 OSD settings

You can operate the FP screen menus via the touch panel, and adjust screen image display to a minute level. The feature is called OSD (On Screen Display). For details,

**Reference** *FP3700-T41 User Manual 3.3.3 Calibration of OSD Display Position*

## 7 Wiring

### WARNINGS

- To avoid an electric shock, when connecting the FP's power cord terminals to the power terminal block, confirm that the FP's power supply is completely turned OFF, via a breaker, or similar unit.
- To avoid the dangers of fire, electric hazards and equipment damage, be sure to use only the specified voltage when operating the FP.
- Since there is no power switch on the FP unit, be sure to attach a breaker-type switch to its power cord.



AC Connector\*1

- \*1 *L : AC Input Terminal-live line*  
*N : AC Input Terminal-neutral line*  
*FG : Ground Terminal connected to the FP chassis*



**The Power Cord included in the FP unit's package is designed only for AC100V or AC115V use. Any other voltage will require a different cord.**

### ■ Installing the AC Power Cord Clamp

#### ◆ Attaching the AC Power Cord

- 1) Open the AC Power Cord Clamp and insert the AC Power Cord as shown in fig. 1. Then, close the Cord Clamp until it clicks into place and locks around the AC Power Cord Collar.



**The Cord Clamp has four teeth for locking. These are to adjust the amount of grip used to hold the AC Power Cord Collar.**

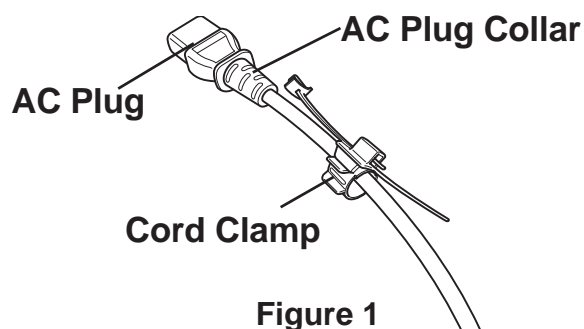
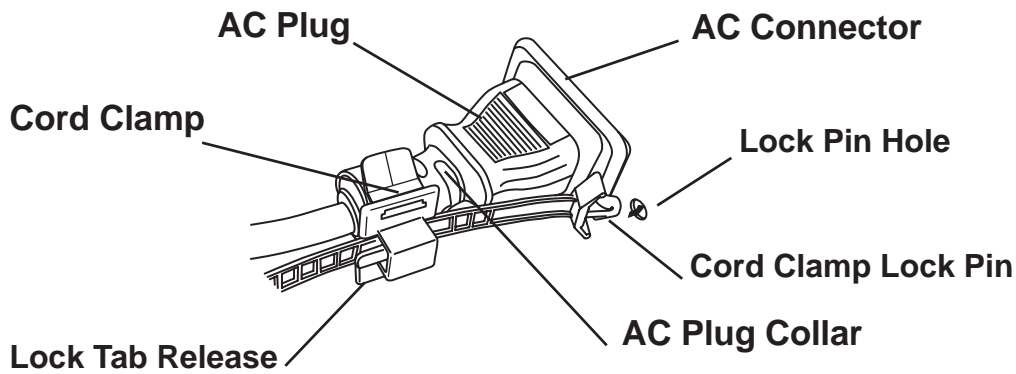

Figure 1

2) Connect the AC plug to the FP unit's AC connector, as shown in fig. 2.



**Figure 2**

3) Insert the Cord Clamp Lock Pin into the FP unit's Lock Pin Hole.

4) Adjust the Lock Pin's Lock Tab length until it is securely held.

### ◆ Removing the AC Power Cord

5) While lifting up on the Lock Pin's Lock Tab Release, pull the AC Plug, Plug Collar and Cord Clamp backwards to disconnect it from the FP unit.

6) Open the Cord Clamp (opposite of step 1) and remove the AC Power Cord from the Cord Clamp.

---

## 8 Using the USB Cable Strap

### USB Cable Strap Attachment Procedure

1) Connect the USB cable to the connector.

2) Insert the cable strap into the cable strap holder as shown in figure 1, and tighten the strap until the cable is secured in place.

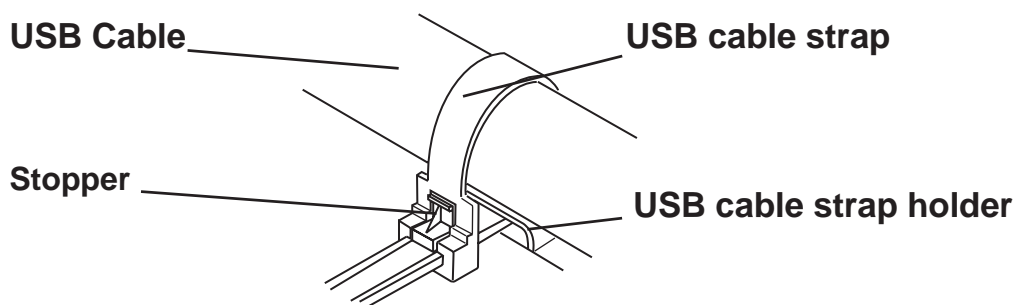

**Figure 1**

### USB Cable Strap Removal Feature

3) Push in the cable strap's stopper until the cable strap band is unlocked, then remove the band.

4) Disconnect the USB cable.

## 9 Power Supply Cautions

Please pay special attention to the following instructions when connecting the power cord terminals to the FP unit.

- If the power supply voltage exceeds the FP unit's specified range, connect a voltage transformer.
- Between the line and the ground, be sure to use a low noise power supply. If there is still an excessive amount of noise, connect a noise reducing transformer.
- Input and Output signal lines must be separated from the power control cables for operational circuits.
- The FP unit's power supply cord should not be bundled with or kept close to main circuit lines (high voltage, high current), or input/output signal lines.
- Connect a surge absorber to handle power surges.
- To reduce noise, make the power cord as short as possible.

## 10 Grounding Caution

When attaching a wire to the FP unit's rear face FG terminal, (on the AC Connector), be sure to create an exclusive ground.\*1

## 11 Input/Output Signal Line Cautions

- All FP Input and Output signal lines must be separated from all operating circuit (power) cables.
- If this is not possible, use a shielded cable and ground the shield.

## 12 Replacing the Backlight

The FP unit's backlight is user replacable.

For an explanation of how to replace the FP unit's backlight, please refer to the backlight's Installation Guide.

### Corresponding Replacement Backlight

FP Model No.	Backlight Model
FP3700-T41	CA3-BLU15-01



***Use of a different model backlight may cause a FP malfunction or breakdown.***

\*1 *Use a grounding resistance of 100Ω, a wire of 2mm<sup>2</sup> or thicker, or your country's applicable standard.*

### Note

Regardless of the above clause, Digital Electronics Corporation shall not be held responsible for any damages or third-party claims for damages or losses resulting from the use of this product.

Digital Electronics Corporation

8-2-52 Nanko Higashi, Suminoe-ku, Osaka 559-0031, Japan

URL: <http://www.pro-face.com/>